

heatmiser®



Model: **DT-ETS WiFi**

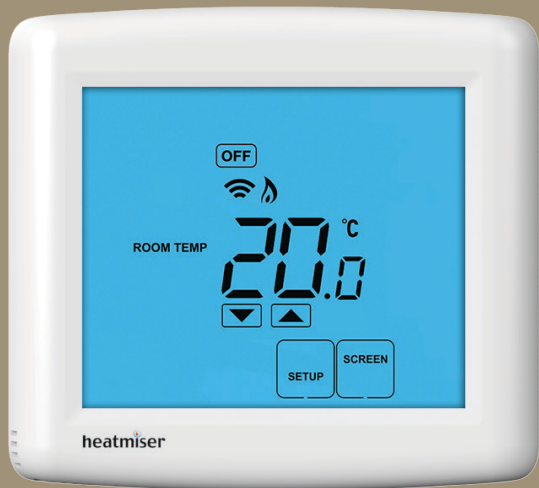

Table Of Contents

Product Image	1	Locking the Keypad	15
Table of Contents	2	Temperature Control	16
What is a Room Thermostat?	3-4	Frost Protection	17
Installation Procedure	5-6	Heating ON/OFF	18
LCD Display	7-8	Optional Features Explained	19-20
WiFi Setup	9-11	Adjusting the Optional Settings	21
Security Types and Compatibility	11-12	Optional Settings - Features Table	22
Remote Access Via App	13	Re-calibrating the Thermostat	23
Remote Access Via Web Browser	13	Factory Reset	24
Temperature Display	14	Wiring Diagrams	25-26
Clean Screen	15		



What is a Room Thermostat?

A room thermostat simply switches the heating system on and off as necessary.

It works by sensing the air temperature, switching on the heating when the air temperature falls below the thermostat setting, and switching it off once this set temperature has been reached.

Setting a room thermostat to a higher temperature will not make the room heat up any faster. How quickly the room heats up, depends on the design & size of the heating system.

Similarly reducing the temperature setting does not affect how quickly the room cools down. Setting a room thermostat to a lower temperature will result in the room being controlled at a lower temperature, and saves energy.

The way to set and use your room thermostat is to find the lowest temperature settings that you are comfortable with, and then leave it alone to do its job.

The best way to do this is to set the room thermostat to a low temperature – say 18°C, and then turn it up by 1°C each day until you are comfortable with the temperature. You won't have to adjust the thermostat further.

Any adjustment above this setting will waste energy and cost you more money.

Room thermostats need a free flow of air to sense the temperature, so they must not be covered by curtains or blocked by furniture. Nearby electric fires, televisions, wall or table lamps may also prevent the thermostat from working properly.

This model DT-ETS thermostat has been specifically designed to operate with electric underfloor heating systems.

Model DT-ETS is also equipped with different temperature sensor options to control the electric underfloor heating system. The thermostat's built in sensor measures the air temperature at the thermostat position within the room and uses measured values to control the electric underfloor heating system. Alternatively, optional remote air and floor sensors can be connected with DT-ETS and remote temperature measurements can be used instead to control the electric underfloor heating system. The thermostat enables easy switching between sensor modes providing a remote air sensor is connected.

Please read the instructions fully to understand all of the features of this DT-ETS thermostat.



Installation Procedure



Do
Mount the thermostat at eye level.
Read the instructions fully so you get the best from our product.



Don't
Do not install near to a direct heat source as this will affect functionality.
Do not push hard on the LCD screen as this may cause irreparable damage.

This WiFi Series thermostat is designed to be flush mounted and requires a back box of 35mm (minimum depth) to be sunk into the wall prior to installation.

Step 1

Carefully separate the front half of the thermostat from the back plate by placing a small flat head terminal driver into the slots on the bottom face of the thermostat.

Step 2

Place the thermostat front somewhere safe.
Terminate the thermostat as shown in the diagrams on pages 25-26 of this booklet.

Step 3

Screw the thermostat back plate securely into the back box.

Step 4

Clip the front of the thermostat back onto the thermostat back plate.

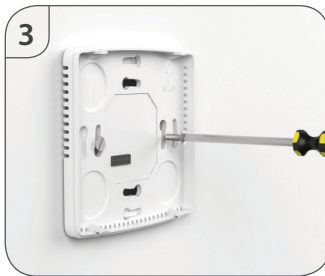
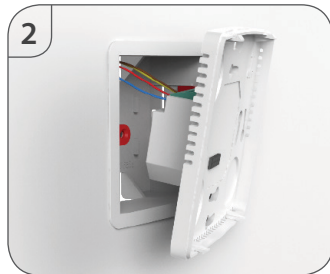



Setting Up Your WiFi Thermostat

Step 1:

Download and install the WiFi thermostat setup utility from our web site: www.heatmiser.co.uk/wifi

Step 2:

Connect the thermostat to your PC with the USB cable provided. This will power the thermostat through the USB port and will allow you to test the WiFi connection. Open the setup utility and press Read to view the current thermostat configuration.

Step 3:

Enter the SSID, Security Type and Security Code of your wireless network. These settings can usually be found on the underside of your wireless router. For more information please consult your router manual. See page 11 for additional information on security types and compatibility.

Step 4:

Enter a fixed IP address for your WiFi thermostat outside of the router DHCP range. It is likely that your network will be configured to operate on a DHCP basis. This means your router automatically issues an IP address to a device that successfully connects to the network.

Your WiFi thermostat needs a fixed IP address in order for local and remote access to operate and you must set this up manually.

Log into your wireless router and navigate to the LAN settings page.

Find and select the DHCP setup details.

This should define the IP range that can be assigned to devices connecting to the network.

As an example, you may have an IP starting range 192.168.1.1 and ending 192.168.1.99. This means you can safely provide your WiFi thermostat the IP address 192.168.1.100 as no other devices will be assigned this address by the router.

If your DHCP range is from 192.168.1.1 to 192.168.1.253 you cannot use 254 or above.

You need to change the DHCP range, taking care not to change any of the first 3 numbers.

***Tip!** When setting up an IP address, the first three sets of numbers must be the same as the router IP address and the fourth set must not be used elsewhere on the network.*

Step 5:

Enter the Subnet mask for the network. This information can usually be found on the underside of your wireless router.

Step 6:

Enter the IP address of your gateway and DNS. In most cases, this is the IP address of your wireless router.

If you have a multi-zone system and are using the Multi-Link, the Gateway of the thermostat will need to be configured as the IP address of the Multi-Link.

Step 7:

Create a unique username and password that will be used to access your thermostat from a web browser.

Default Username: admin

Default Password: admin

Change these settings to your personal preference and record for future use.

A 4 digit access PIN is required to use the smartphone/tablet app and also helps to secure your system.

Step 8:

When you have entered the details of your WiFi network press Apply and disconnect the USB cable, (the thermostat LCD should go blank).

Reconnect the USB cable to the WiFi thermostat, when the thermostat has rebooted it will attempt to connect to your network. This process takes approximately one minute and is complete when the WiFi symbol is displayed on screen.



Security Types and Compatibility

The WiFi Thermostats operate on the 802.11b standard.

If your router is a G model, you must ensure it is setup to work in B&G mode.

You will not be able to connect to your thermostat without changing this setting on G model routers.

There are currently 4 common methods of securing your wireless connection:

OPEN/DISABLED (not recommended)

W.P.A. (medium security)

W.E.P. (lowest security level)

W.P.A.2. (highest security)

Your choice of security settings in the thermostat must match the setting in your router. Often you will find WPA and WPA2 are a single option in the router. This is perfectly normal as the router automatically selects the correct security level and you can set the thermostat up using either one of these settings.

Passwords can be up to 63 characters in length including spaces _ . / \ characters. The W.E.P. option is not so simple. Some routers generate a hidden password from a pass phrase whilst others require a 10 or 26 digit hex password and won't accept anything else. Your thermostat utility can deal with both options but the following restrictions may apply:

A hex password can only be made up of the numbers 0 to 9 and the letters a to f (lower case only).

Hex passwords can only be 10 characters or 26 characters in length.

If a passphrase is used it must be either 5 or 13 characters in length but can be any letter or number.

Your thermostat will automatically calculate the same hidden password your router creates from the same phrase.

These restrictions are common to most routers but you should refer to the router manual for specific restrictions that apply to your model.



Remote Access via App

To remotely connect to your WiFi Thermostat you must forward a port within your router to your WiFi Thermostat.

As all routers are setup differently, you should consult your user manual or the manufacturer's website for more information.

Generally you should create a new service within your router. Within this service you must open **TCP port 8068**.

Use the port forwarding function to forward the new service to the IP address of your WiFi thermostat.



Remote Access via Web Browser

To remotely access your WiFi Thermostat via a web browser you must first open port 80 and forward this to the IP address of your WiFi Thermostat.

To connect to your thermostat, open your preferred browser and enter the IP address that you gave the thermostat during setup and press enter.

You will be asked to enter a password and username. These are both set to "admin" as default.

We recommend you change these settings to ensure the security of your system.

For further information, click the help link within the browser.



Temperature Display

The temperature display information is driven by two different inputs; the sensor measurement and the target temperature you have set.

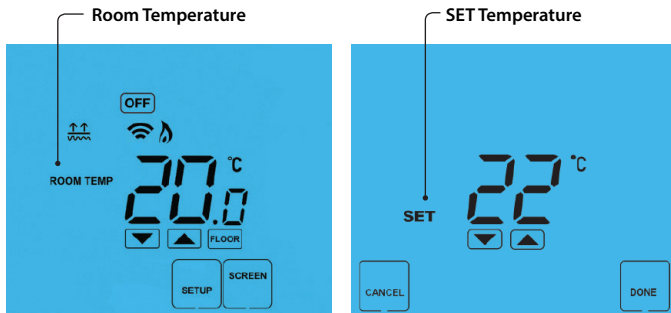

This is the current room temperature.

This is the temperature you are trying to achieve in your home.

When the thermostat is in air and floor sensing mode, the thermostat will display a FLOOR button. Pressing this allows you to view the current floor temperature. Pressing FLOOR again will return the thermostat to the room temperature display.



Clean Screen

Pressing **SCREEN** will disable all keys, providing you 15 seconds to wipe the screen clean before the keys are re-activated.



Locking the Keypad

The thermostat has a keypad lock facility.



- To activate the lock press the bottom right corner of the display and hold for 10s.
- When activated, you will see the Keypad Lock symbol. 
- To cancel, press the bottom right corner of the display again for 10 secs.



Keypad Lock Indicator



Temperature Control

The   keys under the temperature display allow you to adjust the set temperature.

When you press either of these keys, you will see the temperature and the word SET appear on screen.

Select the desired temperature and press **DONE** to confirm and exit.

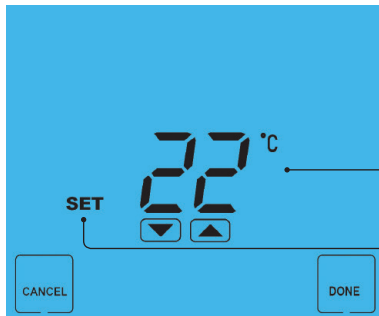

Set Temperature

Set Icon



Frost Mode

Pressing the **OFF** key once will place the thermostat in frost protect mode.

In this mode, the thermostat will display the frost icon and will only turn the heating on should the room temperature drop below the set frost temperature (see page 19).

Should the heating be turned on whilst in frost mode, the flame symbol will be displayed.

To cancel the frost protect mode, press the **OFF** key once.

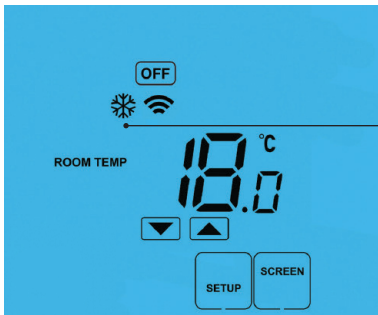

Frost Protection Mode Enabled



Heating On/Off

The heating is indicated ON when the flame icon is displayed.

When the flame icon is absent, there is no requirement for heating to achieve the set temperature but the thermostat remains active.

To turn the thermostat OFF completely, press and hold the OFF key **OFF**
The display and heating output will be turned off completely.*

To turn the thermostat back ON, press the ON key once **ON**

Thermostat completely OFF



Thermostat powered ON



*See Feature 3 on page 19



Optional Features Explained

THE FOLLOWING SETTINGS ARE OPTIONAL AND IN MOST CASES NEED NOT BE ADJUSTED

Feature 01 – Temperature Format: This function allows you to select between °C or °F.

Feature 02 - Switching Differential: This function allows you to increase the switching differential of the thermostat. The default is 1°C which means the thermostat will switch the heating on 1°C below the set temperature and will turn it off when the set temperature is achieved. With a 2°C differential, the heating will switch on 2°C below the set temperature and will switch off when the set temperature is achieved.

Feature 03 - Frost Protect: You can set whether the thermostat will maintain the frost temperature when the thermostat display is turned off. As a default, this is enabled.

Feature 04 – Frost Protect Temperature: This is the temperature maintained when the thermostat is in frost mode. The range is 07-17°C. The default is 12°C and is suitable for most applications.

Feature 05 – Output Delay: To prevent rapid switching, an output delay can be entered. This can be set from 00 - 15 minutes. The default is 00 which means there is no delay.

Feature 06 – Not used on this model.

Feature 07 – Temperature Up/Down Limit: This function allows you to limit the use of the up and down keys. This limit is also applicable when the thermostat is locked and so allows you to give others limited control over the heating system.

Feature 08 – Sensor Selection: This thermostat offers 5 sensor modes.

00 = Built in air sensor. In this mode, the thermostat will maintain the set temperature by monitoring the built in air sensor.

Note: Built in air sensor only MUST NOT be used to control electric under-floor heating. Floor sensor only or built in air & floor sensor together must be used.

01 = Remote air sensor. In this mode, the thermostat will maintain the set temperature by monitoring the remote air sensor.

02 = Floor sensor. In this mode, the thermostat will maintain the set temperature by monitoring the remote floor temperature.

03 = Floor sensor and built in air sensor. In this mode, the thermostat will maintain the set temperature by monitoring the built in air sensor and will also ensure the floor surface doesn't overheat by monitoring the remote floor sensor.

04 = Floor sensor and remote air sensor. In this mode, the thermostat will maintain the set temperature by monitoring the remote air sensor and will also ensure the floor surface doesn't overheat by monitoring the remote floor sensor.

Feature 09 – Floor Limit Temperature: This function allows you to set a maximum floor temperature in order to protect the floor surface from overheating. This function works for Sensor Modes 03 & 04 (see above) The default setting is 28°C.





Adjusting the Optional Settings

To adjust the optional settings, follow these steps.

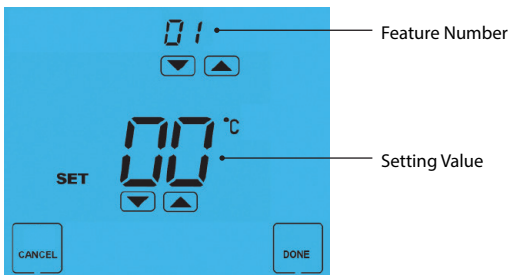
- Press SETUP 



- Use the Up/Down keys at the top of the screen to select the feature number (shown on page 22) and then use the Up/Down keys in the center to adjust the setting 
- Press DONE to confirm settings and exit 



Optional Settings - Feature Table

FEATURE	DESCRIPTION	SETTING
01	Temperature Format	00 = °C 01 = °F (°C = Default)
02	Switching Differential	0.5° - 3.0°C (1.0°C = Default)
03	Frost Protect	00 = Disabled 01 = Enabled (01 = Default)
04	Frost Protection Temperature	07° - 17°C (12°C = Default)
05	Output Delay	Enter Value: 00 - 15 Minutes (00 = Default)
06	Not used on this model	
07	Up/Down Temperature Limit	00° - 10°C (00°C = Default)
08	Sensor Selection	00 = Built in Air Sensor 01 = Remote Air Sensor 02 = Floor Sensor 03 = Floor Sensor and Built in Air Sensor 04 = Floor Sensor and Remote Air Sensor
09	Floor Temperature Limit	20-45°C (28°C = Default)



Re-calibrating the Thermostat

If you need to re-calibrate the thermostat, follow these steps.

- Press and hold the OFF key to turn the thermostat off
- Press and hold the ON key until the temperature appears on the screen
- Use the Up/Down keys to configure the new temperature
- Press DONE to confirm the new temperature
- Press the ON key once to turn the thermostat back on

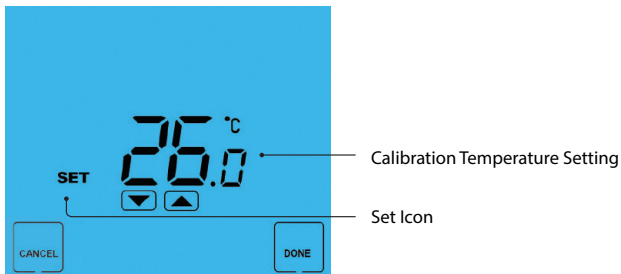

Factory Reset

The thermostat has a reset function to restore all settings to their factory defaults.

To perform a factory reset, follow these steps.

- Turn the thermostat OFF by pressing and holding the Power key. Press and hold the bottom left corner of the LCD for 10 seconds
- All of the screen icons will appear for 2 seconds and then disappear.
- Press the ON key once to turn the thermostat back on

All icons displayed simultaneously.

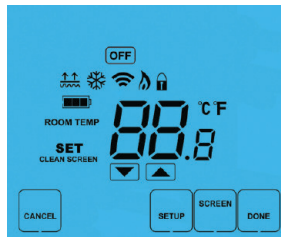

Factory reset is complete.

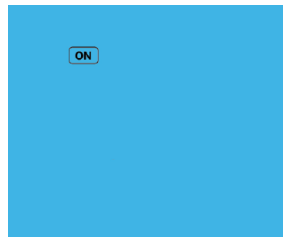



Wiring Diagram - DT-ETS WiFi Wired with Remote Floor Probe

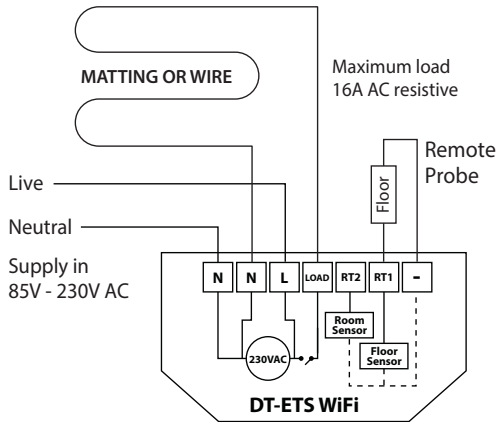

DT-ETS WiFi wired with remote floor probe used for normal 'dry' zones or where direct control of the floor is needed.



Wiring Diagram - DT-ETS WiFi Wired with Remote Floor and Air Probes

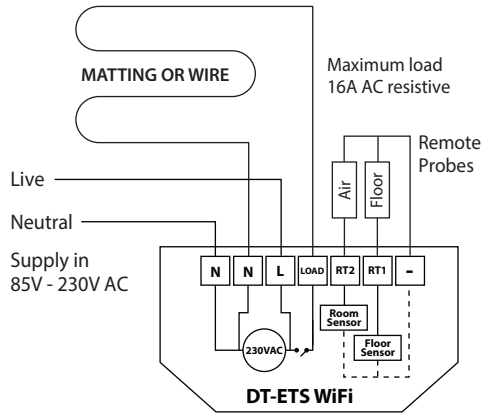

DT-ETS WiFi with remote floor and air probes for use in wet areas. N.B. The mains supply must be properly protected and fused.



Heating Professionals:
Request a copy of our product installation guide containing detailed technical specifications for our complete product range:
www.heatmiser.com/guide

Want More Information?

Call our support team on: +44 (0)1254 669090

Or view technical specifications directly on our website:
www.heatmiser.com



PDF



FAQ



Twitter: [heatmiseruk](https://twitter.com/heatmiseruk)



Facebook: facebook.com/thermostats